

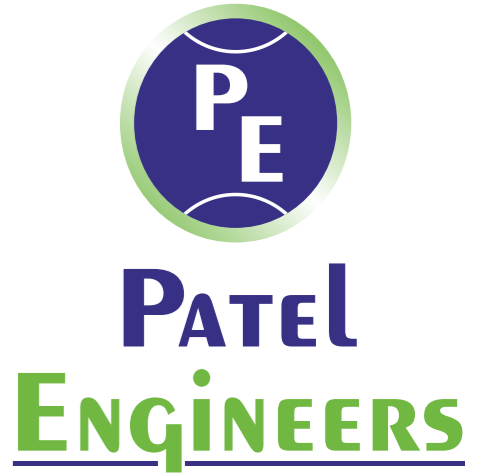

PATEL ENGINEERS
COATING • DRYING • LAMINATING • PRINTING

Plot No. A-2 / 6016, 4th Phase, G.I.D.C Vapi - 396 195, Gujarat, India. Tel.: +91-260-245 11 32
Email : patel_1987@hotmail.com • Website : www.patelengineers.net



COATING

DRYING

PRINTING

LAMINATING

HIGH SPEED STIRRER

We offers complete range of equipment for colors & pigments for mixing department. We can provide you long life machines , save your power consumption, time and increase production.

Hi speed stirrers is a common pre-mixing & dispersing equipment . the mixing shaft can be hydraulic lifting, disc linear speed can normally variable speed inverter adjusting.

Widely used in production line of Pvc resin, coating, ink, paint, white glue, adhesive, silicon, pigments, this machine usually working with our three roller mill.



Main Features

- High Speed Mixing
- Various Types Of Impellers
- Hydraulic Lifting Arrangement
- A.C. Variable Drive For Speed & RPM Can Be Controlled
- Most Efficient Stirring & Rotating

MODEL	PE -HS7.5	PE-HS10	PE-HS15	PE-HS20
Motor power (K.W)-(H.P)	5.5 - 7.5	7.5 - 10	11.1 - 15	14.9 - 20
Speed (R/min)	0-1440	0-1440	0-1440	0-1440
Diameter	250	350	400	450
Lift (mm)	1000	1000	1000	1000
Pump power	2 H.P	2 H.P	2 H.P	3 H.P
Capacity	200	400	600-1000	1000-2000



IMPELLERS



HYDRAULIC HIGH SPEED STIRRER

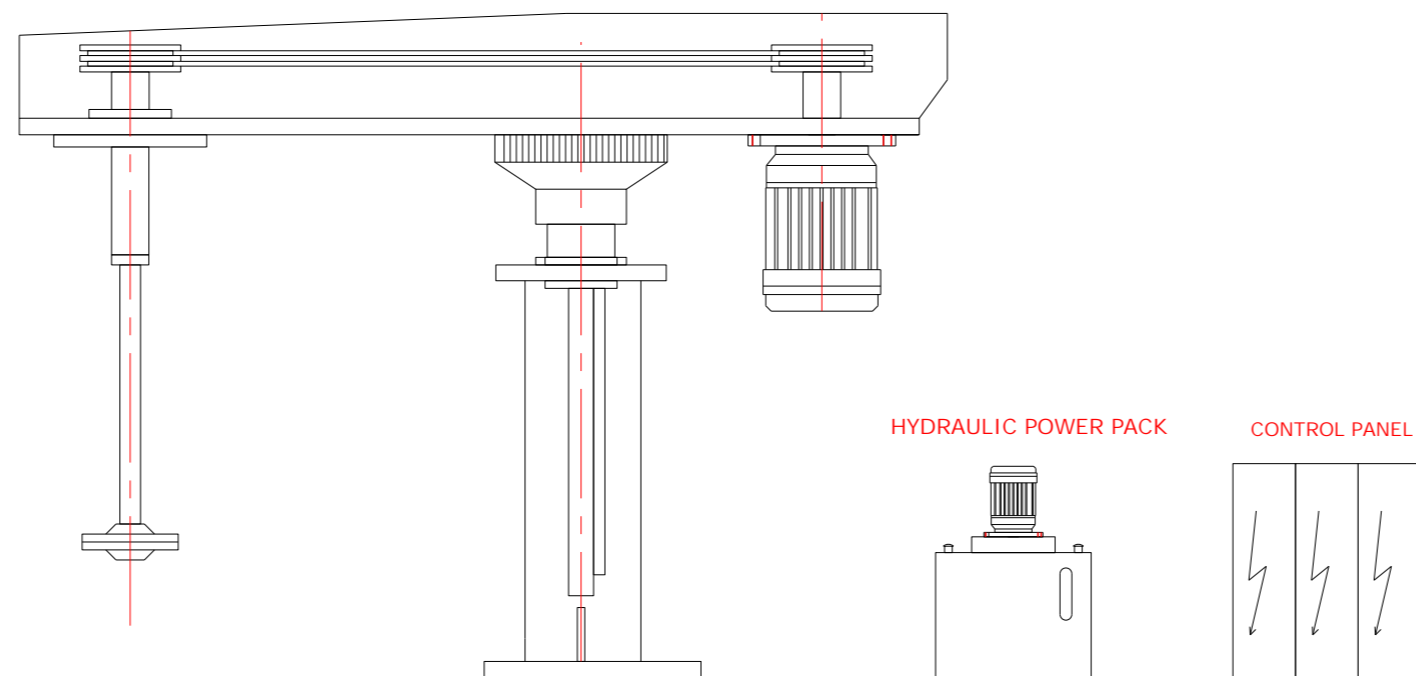

gum cooking pan slow speed stirrer



planetary mixer



gum cooking pan with high speed stirrer